



BHI.2.700 with a D100 pressure gauge on orientable elbowed coupling

Description

Designed for the supply of single-acting cylinders, the hand pumps in the BHI range are equipped with automatic dual-flow rate injection pumps enabling instantaneous transition from the fast approach speed to the working speed. Each pump has a braking valve for controlled load descent, an adjustable internal pressure limiter, and a connector for a pressure gauge.

Specifications

- Working pressure 700 to 1500 bar
- Effective oil tank capacity 1 to 60 litres
- Single-piece light alloy body
- Automatic dual-flow rate pump with internal pressure limiter
- Braking valve for controlling load descent
- Detachable pumping lever, lockable in low position
- Lever high position return spring
- Pressure gauge connector
- Stabilisation lug

On request

- Pressure calibration to other values
- Quick couplers with metal protective cap
- Adjustable external pressure limiter
- Distribution unit for supplying multiple cylinders
- Greater capacity
- Pressure gauge
- Foot-operated control
- Use with Skydrol type fluid

BHI.1 - BHI.2 - BHI.4C - BHI.5C

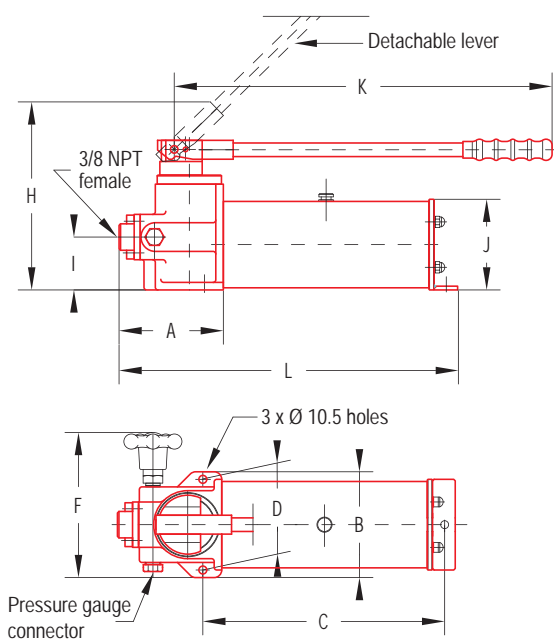

BHI.4 to BHI.60

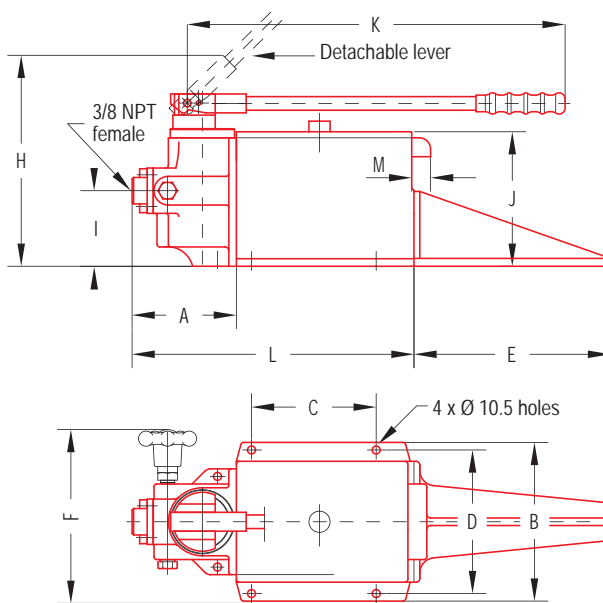

P/N	Mass kg	Eff Cap in litres	Dimensions in mm												Flow rate cm ³ per pump activation					
			A	B	C	D	E	F	H	I	J	K	L	M	700 bar		1000 bar		1500 bar	
															LP	HP	LP	HP	LP	HP
BHI.1	9,5	1,2	135	130	340	110		185	215	55	95	500	470		8,6	1,58	8,6	1,58		
BHI.2	12	2	138	140	320	120		190	245	70	116	525	455		21,3	1,85	21,3	1,6	21,3	1,5
BHI.4.C	17	4	138	140	410	120		190	245	70	135	575	545							
BHI.4	18	4	138	210	165	190	250	225	275	100	178	525	375	26						
BHI.5.C	18	5	138	140	505	120		190	250	70	140	575	633							
BHI.8	22	8	138	250	170	230		245	275	100	178	575	485	26						
BHI.15	38	13,7	138	310	300	280		275	275	100	176	575	595							
BHI.20	44	16,6	138	360	300	330		300	275	100	176	575	595							
BHI.25	53	21,6	138	410	350	380		325	275	100	176	575	645							
BHI.30	62	26	138	410	450	380		325	275	100	176	575	745							
BHI.35	66	28,2	138	410	500	380		325	275	100	176	575	760							
BHI.60	125	56,5	138	560	750	530		400	275	100	176	575	1045							